

(No Model.)

2 Sheets—Sheet 1.

W. A. HANCE.
COFFEE MILL.

No. 437,856.

Patented Oct. 7, 1890.

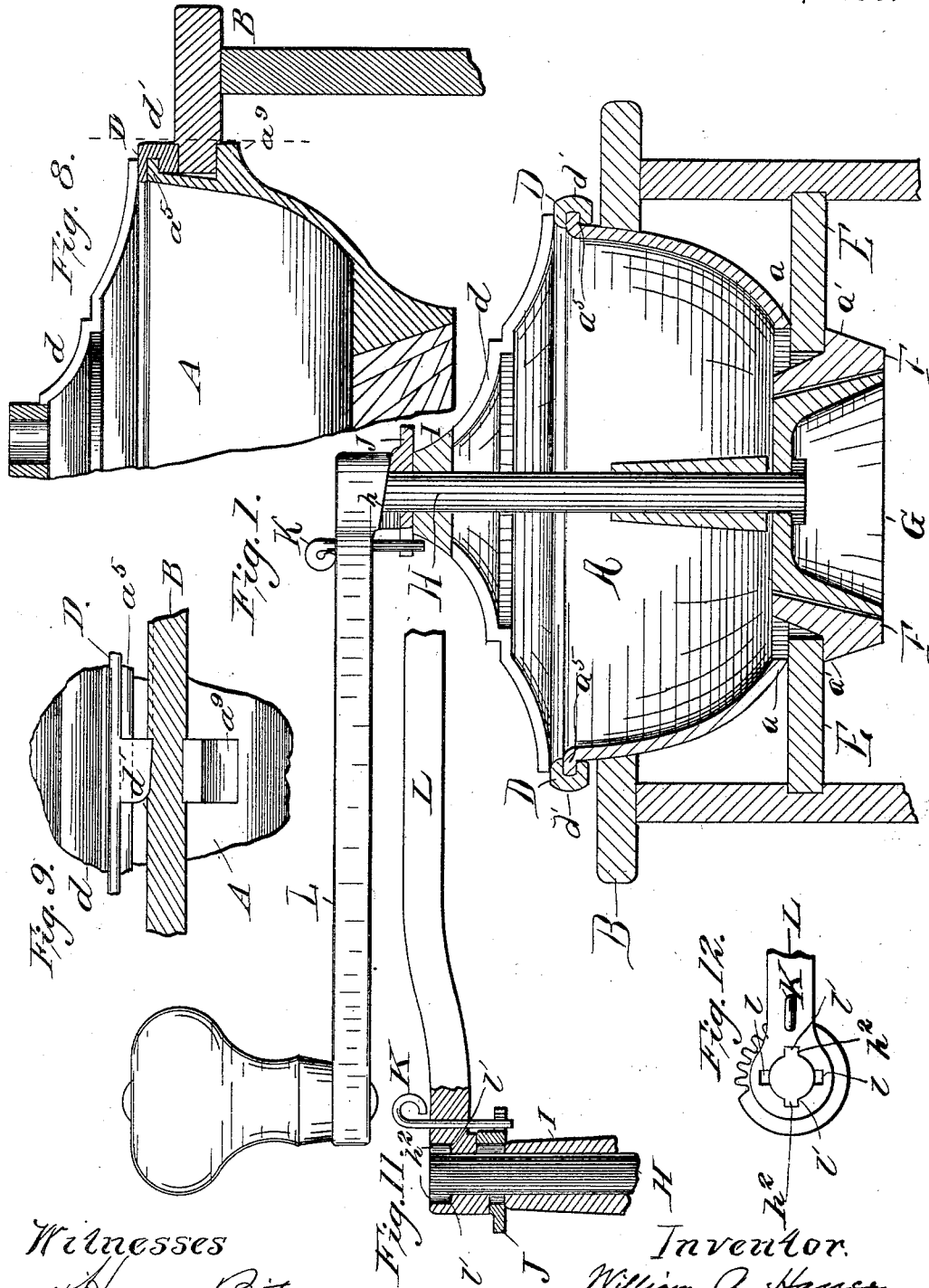

Witnesses
Harry Pitner.
Frank E. Desser.

Inventor.
William A. Hance,
By his attys,
Hill & Dixon.

W. A. HANCE.
COFFEE MILL.

No. 437,856.

Patented Oct. 7, 1890.

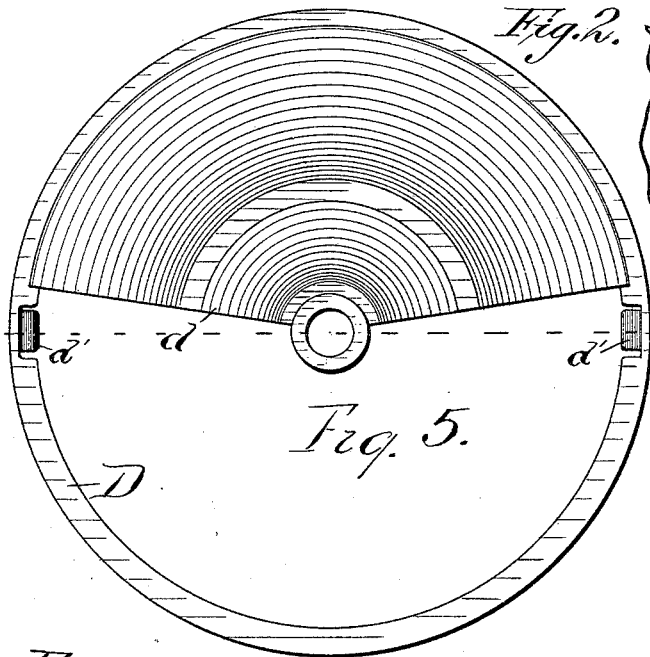

Fig. 2.

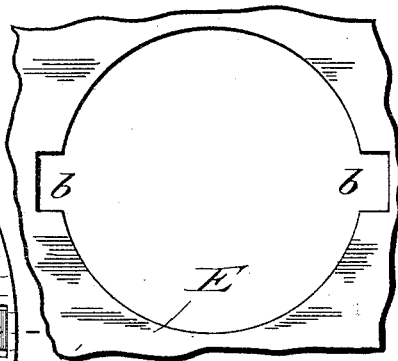

Fig. 3.

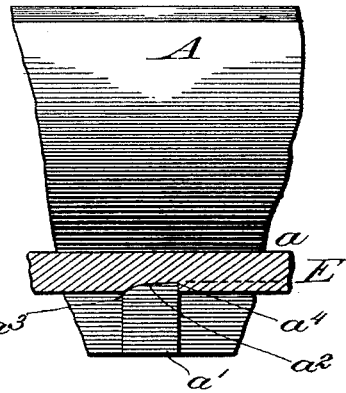

Fig. 6.

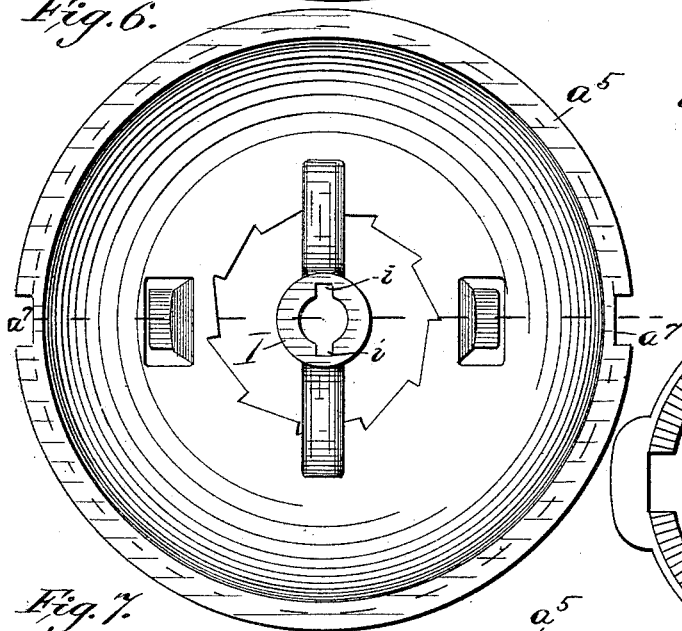

Fig. 4.

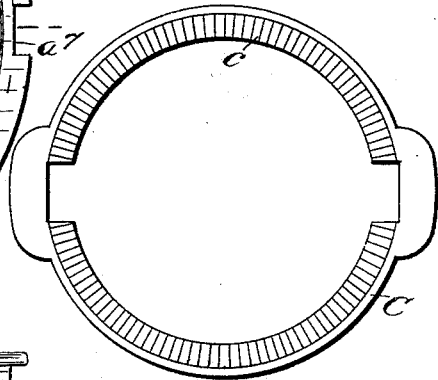
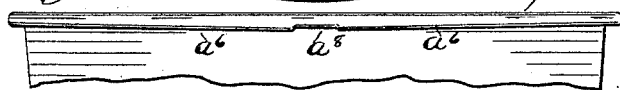
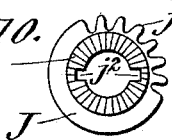

Fig. 7.



Witnesses
H. Bitner
W. Mill

Fig. 10.



Inventor:
 William A. Hance
 By His Atty,
 Hill & Dison.

UNITED STATES PATENT OFFICE.

WILLIAM A. HANCE, OF FREEPORT, ILLINOIS, ASSIGNOR TO THE WARNER
MANUFACTURING COMPANY, OF SAME PLACE.

COFFEE-MILL.

SPECIFICATION forming part of Letters Patent No. 437,856, dated October 7, 1890.

Application filed August 17, 1889. Serial No. 321,115. (No model.)

To all whom it may concern:

Be it known that I, WILLIAM A. HANCE, a citizen of the United States of America, residing at Freeport, in the county of Stephenson and State of Illinois, have made certain new and useful Improvements in Coffee-Mills, of which the following is a description.

In the drawings presented herewith, wherein similar reference-letters indicate the same or corresponding parts, Figure 1 is a central vertical section of a coffee-mill, illustrating certain forms of my improvements; Fig. 2, a view of the portion of the case or box of the mill to which the hopper is attached. Fig. 3 is a detail view, partly in section, showing the manner in which the hopper may be fastened to the box. Fig. 4 is a view of a ring, the use of which is stated below. Fig. 5 is a plan view of the cover of the mill; Fig. 6, a similar view of the uncovered hopper; Fig. 7, a broken side view of the latter. Figs. 8 and 9 illustrate a modification. Fig. 10 is a top view of the washer J, and Figs. 11 and 12 are respectively a vertical section and a broken top view of a modification in the attachment of the handle.

This invention relates to the smaller class of coffee-mills, having for its object certain improvements in the devices employed for fastening the different parts of these mills together, and also in the means provided for the adjustment of the relative positions of the grinding-surfaces, whereby the mill may be given additional strength and rigidity in these particulars and the cost of manufacture may at the same time be materially lessened.

To this end said invention consists in certain features of construction fully described below, and the essential characteristics of which are definitely pointed out in the claims appended hereto.

Referring to the drawings, the hopper A of the mill (see Fig. 1 of the drawings) is cast with a shoulder *a*, adapted to rest upon the top of the box, or, if it is desired to lower the hopper within the box, as here shown, upon a partition E therein, and upon the outer surface of the grinding-shell at a distance below the shoulder *a* sufficient to allow the partition E to be forced between I pro-

vide lugs *a'* of sufficient size to furnish a bearing upon the under surface of the partition E. The number of these lugs is immaterial and may be varied according to the judgment of the manufacturer; but I should recommend the use of at least two as necessary to obtain a firm grip upon the board E. The hole in this board, which is represented in Fig. 2, is notched at *b b* to receive the lugs *a'*, and in putting these parts together said lugs are passed through these notches and the hopper then given a twist, which carries the lugs away from the notches and prevents their return through them.

To secure a firm hold upon the board, I provide an incline upon one of the bearing-surfaces, either upon the upper surface of the lug *a'* or the under surface of the board E, where said lug bears upon it, so that as the hopper is twisted around the board E will be wedged between the shoulder *a* and lug *a'*. This incline I prefer to form on the lug *a'*, where I have lettered it *a²*, inasmuch as the board E is too easily indented for the purpose. This objection may be removed, however, if for any reason it should be considered desirable, by the use of an annular metal washer—such as is shown at C in Fig. 4—between the lug *a'* and the under surface of the board, and in this case I should recommend the placing of the inclined surface upon such washer, as seen at *c c*, so that the inclined or wedging surface may be made as long, and hence as effective, as possible. When the incline is placed upon the lug *a'*, as shown in Fig. 3, I make it quite steep, the lower end being rounded off at the corner *a³* and the upper end terminating in a sharp angle *a⁴*. In twisting the board E upon the hopper the rounded corner *a³* first meets the under surface of the board and is easily forced upon it. The wooden surface is pressed in by the incline *a²*, and as soon as the lug passes over it springs out behind the sharp angle *a⁴* and effectually blocks the return of the lug over the same surface.

To fasten the dome or cover *d* upon the mill, I cast upon the upper rim of the hopper an outwardly-projecting flange *a⁵*, Figs. 1, 6, 7, 8, and 9, with an inclined under surface *a⁶*, Fig.

7, and upon the annular ring D, Fig. 5, commonly used to support the rigid portion of the cover *d*, I provide two downwardly-projecting tongues *d'*, turning inward at the bottom, so as to embrace the flange *a*⁵ between them and the ring D. (See Fig. 1.) In applying the cover these tongues *d'* are passed through notches *a'* in the flange *a*⁵ and twisted around upon the inclined surfaces *a*⁶ as far as their strength will permit and there drop into slight depressions *a*⁸, Fig. 7, formed to receive them and prevent their return.

Figs. 8 and 9 show a modification of my improvement. Here a flat lug *a*⁹ is provided upon the hopper a short distance below the flange *a*⁵, and the tongue *d'* is adapted to wedge between the flange *a*⁵ and the upper surface of the cover B. In this case the lug *a*⁹ may be passed below the board E in the manner described with reference to the lug *a'* in Fig. 1, and the under surface of the tongue *d'* is preferably inclined in the same way as the upper surface of said lug *a'*.

Another improvement applies especially to the adjustment of the distance between the grinding-surfaces upon the grinding-shell F and burr G, Fig. 1, which is necessary in order that the coffee may be ground either fine or coarse, as may be desired. Such adjustment has been commonly made by means of a screw-thread and nut upon the central shaft of the mill. I desire to avoid the constant annoyance due to the tendency of such nut to become loose, and to do this I have employed about the shaft H, Fig. 1, and between a cam-shaped shoulder *h* thereon and the support or journal I, in which said shaft turns, a washer J, Figs. 1 and 10, the under surface of which is flat and adapted to turn easily upon the top of the journal I, and the upper surface of which bears a cam or incline *j*, Fig. 10, fitted to the cam *h* upon the shaft H, so that when the washer is rotated in one direction the cam *h* will ride up the incline *j*, raising the burr

G up toward the shell F, and when rotated in the opposite direction will allow said burr to drop away from the shell. The washer is retained in any position desired by means of a pin K, rigid with the handle L and engaging with the washer by means of teeth *j'* thereon.

In Fig. 1 the handle L is represented as cast integral with the shaft H.

If for any reason it should be deemed best to cast the shaft H and handle L separately, they may be fastened together by means of the devices shown in Figs. 11 and 12, where the lugs *h*² upon the shaft are passed through grooves *l* in the handle and then turned around and dropped into notches *l'* in the same.

I claim as new and desire to secure by Letters Patent—

1. In a coffee-mill, a hopper A, having the flange *a*⁵, notched at *a*⁷ and provided with an incline *a*⁶, in combination with the cover *d* D, bearing the tongues *d'*, as and for the purpose stated.

2. In a coffee-mill, a hopper A, provided with the flange *a*⁵, in combination with the cover *d* D, bearing tongues *d'*, adapted to be wedged beneath the flange *a*⁵, substantially as described.

3. In a coffee-mill, the combination of the hopper A, having the central journal I, the shaft H, holding the burr G and bearing the cam *h*, and the washer J, provided with an inclined face interposed between said journal and said cam, as and for the purpose stated.

4. In a coffee-mill, the combination of the hopper having the supporting-journal I, the shaft H, bearing the cam *h* and the lug *h'*, and the washer J, provided with an inclined face and burr G, all constructed substantially as above set forth.

WILLIAM A. HANCE.

In presence of—

T. R. BARTLETT,
O. J. ZIEGLER.