

P. HOBLER & E. G. GOOD.  
Grinding-Mill.

No. 226,315.

Patented April 6, 1880.

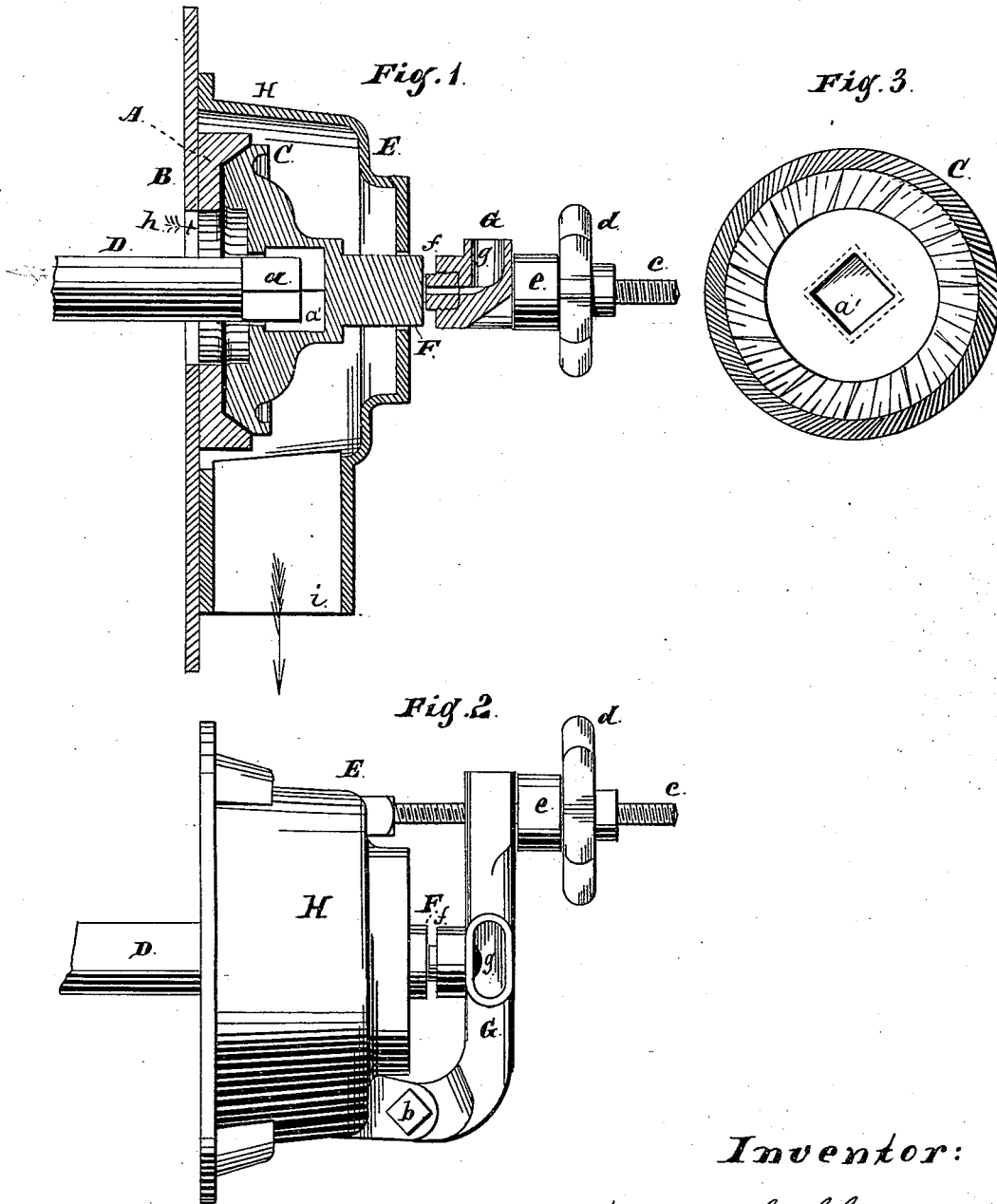

*Witnesses:*  
A. L. Burns  
J. S. Polley Jr

*Inventor:*  
Peter Hobler.  
Edward G. Good.  
By West & Bond Attys.

# UNITED STATES PATENT OFFICE.

PETER HOBLER, OF BATAVIA, AND EDWARD G. GOOD, OF CHICAGO, ILL.,  
ASSIGNORS TO AMERICAN GRINDING MILL COMPANY, OF SAME PLACE.

## GRINDING-MILL.

SPECIFICATION forming part of Letters Patent No. 226,315, dated April 6, 1880.

Application filed August 11, 1879.

*To all whom it may concern:*

Be it known that we, PETER HOBLER, of Batavia, Illinois, and EDWARD G. GOOD, of Chicago, Cook county, State of Illinois, have  
5 invented a new and useful Improvement in Grinding-Mills, of which the following is a full description, reference being had to the accompanying drawings, in which—

Figure 1 is a vertical section. Fig. 2 is a  
10 top view; Fig. 3, an inside view of the loose ring.

It is common to make grinding-rings of cast metal, and to place them, for use, in vertical  
15 instead of horizontal planes. Heretofore the runner or movable grinding-ring has been rigidly secured upon a shaft, and only one adjustment has been provided for to adapt the mill to grind fine or coarse.

The object of our invention is to so construct  
20 the mill that the movable grinding-ring, in addition to being adjustable, so as to grind fine or coarse, will have such freedom of movement while grinding that its face will be, from time to time, automatically adjusted relatively  
25 to the face of the fixed grinding-ring, as circumstances may require; and this we accomplish by connecting the grinding-ring loosely to the shaft which drives it, and so that such ring is free to move a little upon the end of such  
30 shaft, so as to bring the grinding-surface nearer to or carry it farther from the fixed ring, and by devices for adjusting the runner so as to grind fine or coarse, as hereinafter fully described.

Another object of our invention is to so construct  
35 the devices used to adjust the ring to grind fine or coarse that in case any small hard substance passes in between the rings the grinder can yield a little, and this we accomplish by the use of a spring in connection  
40 with the adjusting devices.

We have not shown a full mill, but only so much as is necessary to illustrate our invention.

45 In the drawings, A represents a fixed grinding-ring secured to a plate, B, in the usual manner.

C is a movable grinding-ring placed loosely  
50 on the square or many-sided end *a* of a shaft, D, which shaft is supported in suitable bear-

ings, as usual, which are not shown, and such shaft is to be driven in any known suitable manner. As shown, the inner end of the opening in the ring C which receives the end *a* of the shaft is considerably larger than the outer  
55 end, which first receives the shaft. This is not a necessity, but it is desirable, permitting greater freedom of movement of the ring C.

By placing the runner C loosely on its shaft,  
as described, it can be rotated by the shaft  
60 and yet have, to a certain extent, the freedom of movement of a ball-and-socket or other universal joint. This ring is made quite thick at the center to provide a chamber for the end  
65 of the shaft D, and upon the outer face and centrally located is an extension, F, which passes loosely through the case E, which incloses the rings, to avoid friction and wear,  
70 but sufficiently close to prevent the runner from tipping too far.

G is a bridge-tree, hinged at one end, *b*, to  
the case E. The other end passes over a screw-threaded rod, *c*, secured to the case E.  
75 *d* is a hand-wheel and nut on *c*, and *e* is a rubber or other suitable spring upon *c*, and between the end of the bar G and the hand-wheel *d*. *f* is a projection or stud on the inside of the bar G, so arranged that it comes  
80 in contact with the end of the projection F on the runner C. *g* is an oil-cup. H indicates the metal case surrounding the runner, and *a'* an opening in the runner inwardly enlarged.

The hopper is not shown, but can be made as usual. The arrow *h* indicates the course of the  
85 grain to the rings, and the arrow *i* is in the exit-passage.

The operation is as follows: While the runner C is in motion it is free to adjust itself relatively to the face of the fixed ring A, because  
90 its connection with the end of its driving-shaft is practically a universal joint. This is desirable for at least two reasons: first, because in casting the rings they are likely to have faces which are not exactly true, and if the runner is rigidly secured to its driving-  
95 shaft the grinding will be uneven and the rings will be likely to come in contact with each other at some point when set for fine grinding; and, second, it is desirable in order  
100 to permit the runner to yield a little upon one

side to accommodate itself to any small foreign substance which may pass into the mill.

We are aware that it is not new to place a runner or grinding-ring sufficiently loose upon its driving-shaft to permit an end adjustment thereon; but we are not aware that such a runner has been cut away, so that at the point of connection with the driving-shaft a tipping movement of the runner is permitted; and we are not aware of any mill having a hinged and spring bridge-tree with its bearing-point so connected with the runner that the runner is free to move across the adjusting-bearing within proper limits, and it will be seen that it is important to have a spring bridge-tree to permit the movement across the end bearing in order to prevent cramping and undue wear.

The inner face of the bridge-tree G, or the stud *f* thereon, comes in contact with the projection F and holds the runner to its place, and by means of the hand-wheel the runner can be adjusted to grind fine or coarse. The adjustment is to be such that the spring *e* will not yield under ordinary conditions; but if a piece of metal or other hard substance passes

in between the rings the spring *e* can yield somewhat to relieve the mill.

What we claim as new, and desire to secure by Letters Patent, is as follows:

1. The movable grinding ring or runner C, having the circular projection F and the angular opening *a'*, enlarged at its inner end, in combination with the shaft D, having an angular end, *a*, whereby said grinding-ring, in addition to the ordinary adjustment, is permitted to vibrate or shift its vertical position, substantially as specified.

2. The free adjusting-bearing *f*, in combination with the runner C, having the extension F, and the arm G, hinged to the case, spring *e*, adjusting-nut *d*, and screw *c*, attached to the case, whereby the mill is reduced to a more compact form, and the end of the runner is permitted to play across the end bearing, substantially as and for the purposes described.

PETER HOBLER.

EDWARD G. GOOD.

Witnesses:

E. A. WEST,

JOHN C. POLLEY, Jr.